

# RIB

## 8.0 Series



*Smart Own*

**Do Dubai para o Mundo**

[www.smartown.ae](http://www.smartown.ae) | [info@smartown.ae](mailto:info@smartown.ae) | +971 4 4438970



# Características

## Comprimento Total:

motores não incluídos  
8,2 m (26 ft 11 in)

## Largura Total:

2,55 m (8 ft 4 in)

## Peso do Barco Semirrígido:

1.856 kg

## Carga Útil:

1.441 kg

## Motores de Série:

Yamaha, de popa, 2x150 CV

## Velocidade Máxima:

50 nós

## Potência Máxima Permitida:

2x250 CV

## Depósito de Combustível:

455 l (120 US gal)

## Lotação máxima:

12 pessoas

## Compartimentos estanques:

5

## Material dos Tubos de Flutuação:

Hypalon 1670 DTEX

## Material do Casco e Convés:

PRFV

## Classe: (Aprovação CE)

B

## \*\*HYPALON COLLAR

ASIS uses the finest quality material to manufacture and produce all of its products. Only Hypalon™ is used in the manufacture of the ASIS tube.

**Outside CSM layer gives:**  
> weather resistance - fading and ageing)  
> chemical resistance  
> abrasion resistance

**Layer of Neoprene in between the CSM and the textile.**

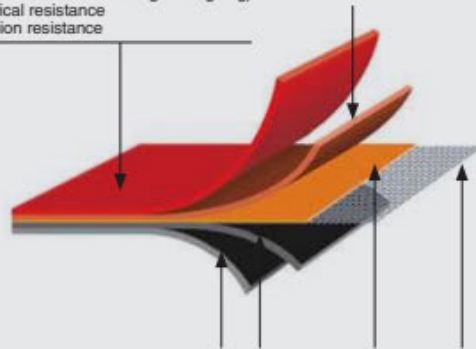

**Inside Neoprene sheets give:**  
> high gluability and reliable adhesion  
> air tightness (no air in the high textile)

**High Tenacity Textile give:**  
> basic mechanical properties (tensile and tear strengths)  
> dimensional stability



RIB 8.0 Series

# Equipamento de Série

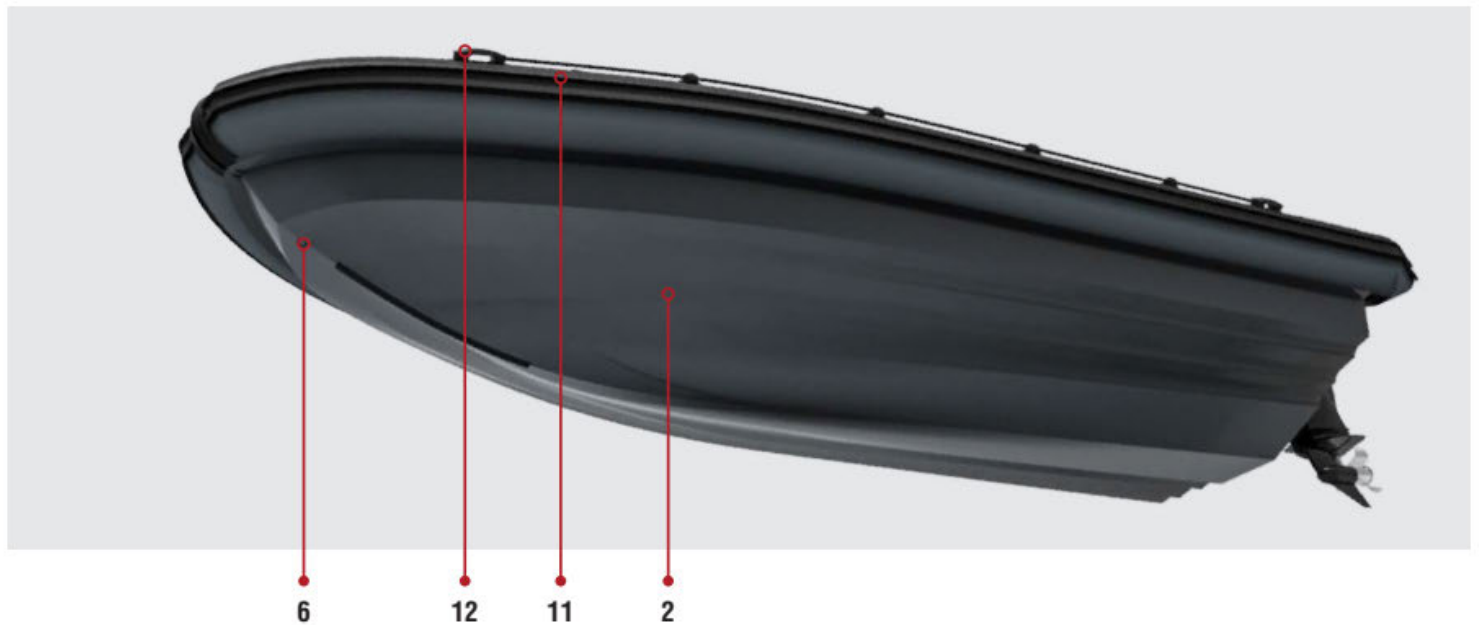
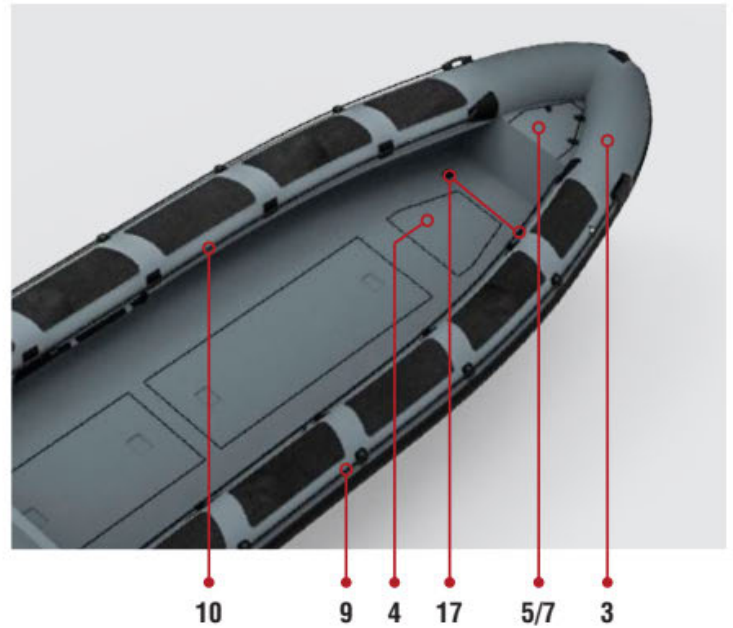
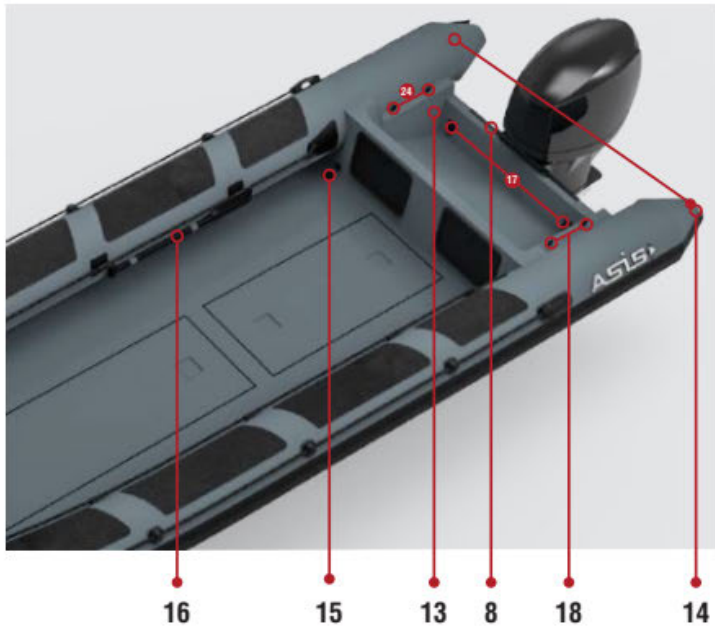

#	STANDARD EQUIPMENT
1	Heavy Duty Structure
2	Custom Color Fiberglass
3	Tube Material Heavy Duty Hypalon 1670 DTEX
4	Under-Deck Storage 3Nos
5	Anchor Locker
6	Bow U Bolt 1No. & Towing Rings 2Nos.
7	Stainless Steel Eye Nut Inside The Anchor Box
8	Stainless Steel Transom Strip
9	External Safety Rope Grab Line
10	Internal Safety Rope Grab Line
11	Large Profile All-Around Double or Triple Rubbing Strake
12	Moulded Handles 4Nos.

#	STANDARD EQUIPMENT
13	Engine Pit
14	Reinforced Cone Ends 2Nos. 2Nos.
15	Self Draining Deck
16	Paddles 2Nos.
17	S.S Heavy Duty Lifting Points (2Nos. on Front & 2Nos. on Back)
18	Stainless Steel Base Pin Connection for A Frame
	<ul style="list-style-type: none"> <li>Stainless Steel 316L Fuel Tank with Gauge and Sender</li> <li>Air Pump</li> <li>Repair Kit</li> <li>Automatic Bilge Pumps 2Nos. with Float Switch</li> <li>Navigation and Anchor Light</li> <li>Switch Panel</li> </ul>

RIB 8.0 Series

# Certificação CE



## EXAMINATION REPORT STABILITY & BUOYANCY

CERTIFICATE NUMBER -06-10-0913-

### Annex I

#### Main particulars of Certified product

Lh: Length of hull (ISO 8666) : 7.70 [m]  
Bh: Beam of hull (ISO 8666) : 2.53 [m]  
T: Maximum draft fully loaded : 0.2 [m] without outboard  
Δ: Displacement fully loaded : 3352 [kg]  
P: Maximum engine power : 2 x 183.5 [kw]  
Maximum engine weight : 600 [kg]  
No. of compartments : 5

#### Tank capacities

Total fuel tank capacity : 250/655 [ltr]  
Total fresh water tank capacity : - [ltr]  
Total black water tank capacity : - [ltr]

#### The Certified product has been assessed on basis of the following

Documentation as in ECB file: ASD-0545/ MAC-0545  
Technical Construction File, kept by Applicant.  
Final reports: MAC-0545 date 12-04-2001; 170322 modifications ASD-0545

#### Information on builders plate of Certified product

Manufacturers name and address : See page 1  
Marking: CE  
Design category: B  
Recommended maximum nr. of persons : 15  
Recommended maximum load: 2000 kg (persons, stores, outboard engines)

List of Essential requirements and related relevant parts of the Technical Documentation (reference to relevant articles in Annex IA & IC of the Directive)	remarks
<b>General requirements (2)</b>	<b>EN ISO 8666:2002</b>
Stability and freeboard (3.2)	EN ISO 6185-3:2014
Buoyancy and floatation (3.3)	EN ISO 6185-3:2014 EN ISO 14946:2001

This certificate consists of 1 page and 1 annex

For ECB Nederland,

Signature  
name  
function

H.J. Bloemers, B. Eng  
Senior Executive



ECB Nederland [www.ecb.nl](http://www.ecb.nl) +31(0)299 323123 [info@ecb.nl](mailto:info@ecb.nl)

RIB 8.0 Series

# Exemplos de Configuração

Transporte



RIB 8.0 Series

# Exemplos de Configuração

Segurança pública



RIB 8.0 Series

# Exemplos de Configuração

Militar, patrulha fluvial



RIB 8.0 Series



*Smart Own*

**Do Dubai para o Mundo**

[www.smartown.ae](http://www.smartown.ae) | [info@smartown.ae](mailto:info@smartown.ae) | +971 4 4438970

